

# PE-SAL™

## Station Address Logic Module

Inventra™ Soft Core (RTL IP)

D A T A S H E E T

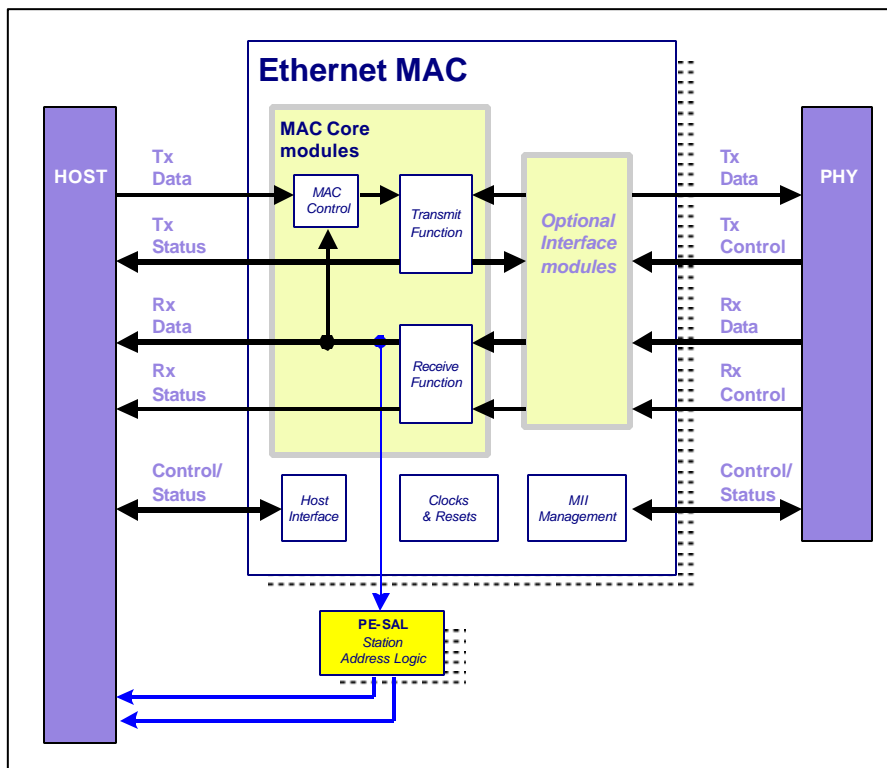

PE-SAL Application

### Overview

The PE-SAL Station Address Logic module accepts the destination address field of incoming packets and all the related control signals and performs an address comparison. According to the requirements of the application, the PE-SAL may be programmed to accept:

- All incoming packets
- All broadcast packets
- All multicast packets
- Qualified multicast packets, or
- Packets addressed to a particular physical address

In addition, the PE-SAL enables its internal 48-bit Station Address Register to be inserted into the transmit data stream through byte multiplexed enabled output.

The PE-SAL module was designed in Verilog and is provided to licensees with a behavioral testbench.

### Major Product Features:

- Designed to integrate with Inventra Ethernet MAC families
- Programmable to accept broadcast, multicast, qualified multicast packets or packets addressed to a specific physical address
- Also enables insertion of recorded address into transmit data stream
- Fully synthesizable
- Scan insertion-friendly design

### Deliverables:

- Verilog source code
- Synthesis constraints files
- Detailed design specification
- Application Note

### Related products:

- PE-MCXMAC 10/100/1000 Ethernet MAC
- PE-MACMII™ 10/100 Ethernet MAC
- PE-RMII™ Ethernet MAC with RMII
- PE-SMII™ Ethernet MAC with SMII
- PE-PMD™ Ethernet MAC with PMD I/F
- PE-ENDEC™ Ethernet MAC with ENDEC Interface
- PE-MSTAT™ Statistics Package

*Mentor Graphics is the leading supplier of a broad range of IP soft cores targeting standards-based communications applications. These highly re-usable cores help systems and chip designers get to market faster.*

## PE-SAL Station Address Logic Module

### Operation

Alongside Receive Packet Data, the receive byte stream contains a CRC, a CRC Qualifier, a Broadcast frame indicator, and a Multicast frame indicator.

The PE-SAL Station Address Logic module accepts or rejects incoming frames on the basis of the address comparison it performs on the frames with a 48-bit source address. A hash table is used to filter multicast packets.

A typical operation of the PE-SAL is as follows. First, the Set Receive Enable is reset (to prevent the MAC's receive function from receiving any frames). The user then programs the required physical address into the Source Address Register.

The user also configures the Address Filter Control Register, depending on the desired frame filter method (see below). One of the options is to accept qualified multicast packets. If this option is selected, the user also needs to program a hash table to indicate which multicast messages are required.

Once these configurations are complete, the user re-enables frame reception.

### Packet Filtering

The address comparison logic in the PE-SAL is enabled through a Receive Enable bit in the PE-SAL's Configuration register. When this bit is clear, all incoming frames are ignored. When this bit is set, the PE-SAL performs the functions described below.

An Address Filter Control Register is used to determine how incoming packets are to be filtered. Four bits select the following conditions: accept all incoming packets (promiscuous mode), accept all multicast packets, accept all

qualified multicast packets (using the hash table), and accept all broadcast packets. If no bits are set in this register, packets will only be accepted if the destination address matches the recorded station address.

When the Address Filter Control Register is programmed to accept all incoming packets, the PE-SAL bypasses the compare logic and sets ACCEPT when CRCG from the PERFUN is High.

When the Address Filter Control Register is programmed to accept all multicast packets, the PE-SAL bypasses the compare logic and sets ACCEPT when CRCG and MCO from the PERFUN are High.

When the Address Filter Control Register is programmed to accept all broadcast packets, the PE-SAL bypasses the compare logic and sets ACCEPT when CRCG and BCO from the PERFUN are High.

When the Address Filter Control Register is programmed to accept all qualified multicast packets, the PE-SAL decodes the upper 6 bits from the CRC generator, selects the corresponding bit from the hash table and either accepts or rejects based on whether the bit is high or the packet has been sent to a broadcast address. The unique broadcast address of all '1's may also be enabled by setting the appropriate bit in this hash table.

When the PE-SAL is set to accept packets from a single physical address, the 48-bit Station Address is compared byte-by-byte with the destination address contained in RPD[7:0]. If all 6 bytes of the destination address match the 6 bytes of the Station Address, the message will be accepted.

When none of the above conditions are satisfied, the packet will be rejected.

© 2001-2004 Mentor Graphics Corporation, All Rights Reserved.

™Mentor Graphics and Inventra are trademarks of Mentor Graphics Corporation.  
All other trademarks are the property of their respective owners.

**Corporate Headquarters**  
Mentor Graphics Corporation  
8005 S.W. Boeckman Road  
Wilsonville, OR 97070 USA  
Phone: 503-685-7000  
**North American Support Center**  
Phone: 800-547-4303  
Fax: 800-684-1795

**Silicon Valley Headquarters**  
Mentor Graphics Corporation  
1001 Ridder Park Drive  
San Jose, California 95131 USA  
Phone: 408-486-1500  
Fax: 408-436-1501

**European Headquarters**  
Mentor Graphics Corporation  
Immeuble le Pasteur  
13/15, rue Jeanne Braconnier  
92360 Meudon La Foret  
France  
Phone: 33-1-40-94-74-74  
Fax: 33-1-46-01-91-73

**Pacific Rim Headquarters**  
Mentor Graphics (Taiwan)  
Room 1603, 16F,  
International Trade Building  
No.333, Section 1, Keelung Road  
Taipei, Taiwan, ROC  
Phone: 886-2-27576020  
Fax: 886-2-2756027

**Japan Headquarters**  
Mentor Graphics Japan Co., Ltd.  
Gotenyama Hills  
7-35, Kita-Shinagawa 4-chome  
Shinagawa-Ku, Tokyo 140  
Japan  
Phone: 81-3-5488-3030  
Fax: 81-3-5488-3031

