

PCI Express to AMBA 2 AHB Bridge IP

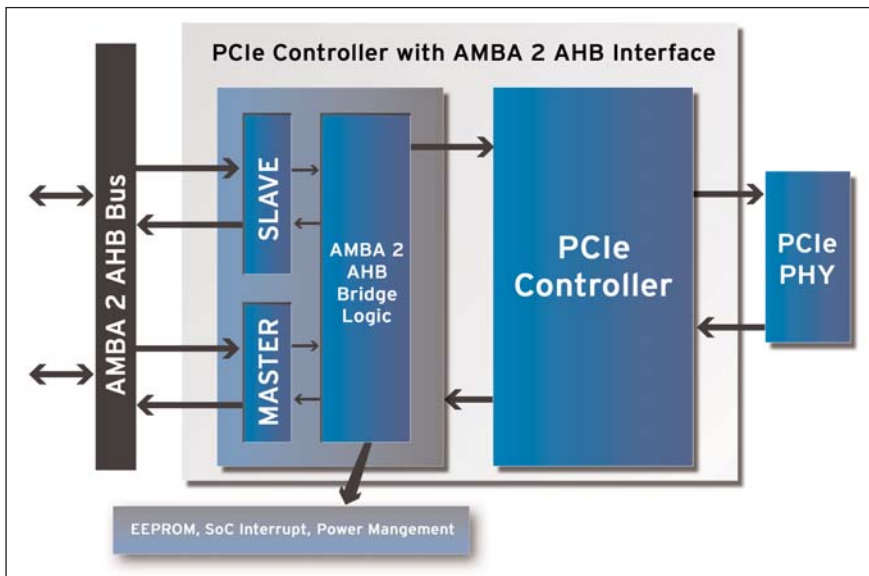

The AMBA 2 AHB bridge is highly configurable with great flexibility to meet the optimal performance requirements demanded by today's silicon designers.

Highly Configurable Bridge Between PCIe and AMBA Bus Protocols

Design challenges are greatly increased when a bridge is required between two sophisticated PCI Express (PCIe) and AMBA bus protocols. A bridge enables higher data throughput and allows multiple system buses to be configured at both ends. Realizing the need of this design challenge, Mentor Graphics created the PCIe to AMBA 2 AHB bridge IP in conjunction with Mentor's PCIe controller IP to provide the end-to-end connectivity between AMBA 2 AHB bus to PIPE-compliant PCIe PHY.

The PCIe to AMBA 2 AHB bridge IP is highly configurable with the flexibility necessary to meet the optimal performance requirements demanded by today's silicon designers. It supports the most advanced features in PCIe technology — power management, QoS, hot-plug/hot-swap, and error handling. The PCIe to AMBA 2 AHB bridge IP also complies to AMBA 2 AHB Protocol 2.0 specifications.

Major product features:

- Fully integrated with Mentor's PCIe controller
- Allows PCIe to be dynamically configured for Root Port or Endpoint at power-up
- Configurable 32-bit or 64-bit datapath AMBA 2 AHB Master/Slave interface
- Local/remote CPU support through concurrent DMA write and read
- Supports MSI or legacy interrupts for PCIe
- Supports system interrupt and error reporting for ARM processors
- Supports 32b and 64b addressing from PCIe to AMBA 2 AHB bus
- User programmable address translation between AMBA 2 AHB and PCIe in both EP and RC mode
- Built-in EEPROM support
- Capable of queuing up to 8 transactions concurrently for high throughput
- Supports all power management states L0, L0s, L1, L2 & L3
- Clock request (Clkreq) mechanism for low power mode in mobile form factors
- Supports all required and optional PCIe power management features

Deliverables:

- Synthesizable Verilog RTL
- Sample testbench for simulation
- Sample synthesis scripts
- Sample static timing analysis
- Documentation

Related products:

- **PCIe to AMBA 3 AXI Bridge IP**
- **PCIe Controller IP:** x1, x2, x4, x8, and x16

Architected by Industry Veterans

The PCIe to AMBA 2 AHB bridge from Mentor Graphics offers a highly scalable and pipelined architecture for low power applications. It features an easily configurable plug-and-play user logic interface for setting the device as either master or slave. In addition, it has an optimized architecture to provide multiple datapath widths, including 32-bit and 64-bit.

Design for test (DFT) and design for debugability (DFD) features are also built in to the architecture of this PCIe to AMBA 2 AHB bridge along with a technology independent design that makes it ideal for ASIC, SoC, and FPGA systems. The bridge's low silicon footprint is suitable for multiple instances of the core in one single silicon design.

Parameterized Core

The PCIe to AMBA 2 AHB bridge offers highly parameterized RTL for easy configurability — depending on requirements. It supports both cut-through and store-and-forward schemes when forwarding transmitted packets. The bridge operates at all allowable speeds down to x1 (1-lane) mode. Selectable ECRC and advanced error reporting support are

also built-in along with configurable Type-0 (Endpoint) or Type-1 (Root Port) configuration headers.

Plug-and-Play Application Interface

The easy-to-integrate interface with user logic offers controllability for critical device parameters. The streamlined user interface provides a reasonable number of interface signals.

Application Coverage

Mentor's AMBA 2 AHB bridge allows embedded devices that are based on the on-chip AMBA 2 AHB bus protocols to use off-chip PCIe technology to drive high-performance chip-to-chip interconnect on applications as depicted in the figure below. These applications include:

- Wireless Devices
- Data Communications
- Telecommunications
- Storage Area Networks
- Graphics Devices
- Consumer Electronics
- Automotive I/O
- Converged Devices (Communication, Information, Entertainment)

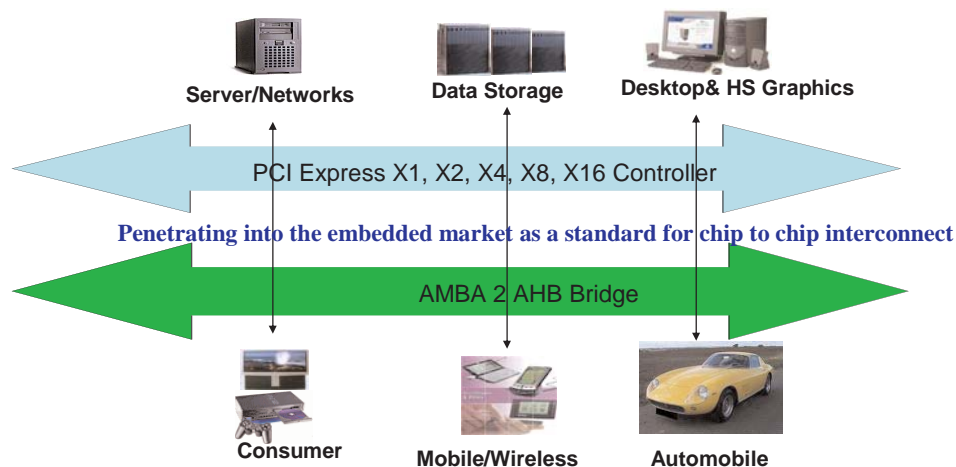

PCIe to AMBA 2 AHB bridge technology helps drive high-performance chip-to-chip interconnect on some of today's more complex applications.

Visit our website at www.mentor.com/ip for additional product information.

© 2007 Mentor Graphics Corporation. All Rights Reserved.

Mentor Graphics is a registered trademark of Mentor Graphics Corporation. All other trademarks mentioned in this document are trademarks of their respective owners.

Corporate Headquarters
Mentor Graphics Corporation
8005 S.W. Boeckman Road
Wilsonville, Oregon 97070 USA
Phone: 503-685-7000
North American Support Center
Phone: 800-547-4303
Fax: 800-684-1795

Silicon Valley
Mentor Graphics Corporation
1001 Ridder Park Drive
San Jose, California 95131 USA
Phone: 408-436-1500
Fax: 408-436-1501

Europe
Mentor Graphics
Deutschland GmbH
Arnulfstrasse 201
80634 Munich
Germany
Phone: +49.89.57096.0
Fax: +49.89.57096.400

Pacific Rim
Mentor Graphics Taiwan
Room 1603, 16F,
International Trade Building
No. 333, Section 1, Keelung Road
Taipei, Taiwan, ROC
Phone: 886-2-27576020
Fax: 886-2-27576027

Japan
Mentor Graphics Japan Co., Ltd.
Gotenya Hills
7-35, Kita-Shinagawa 4-chome
Shinagawa-Ku, Tokyo 140
Japan
Phone: 81-3-5488-3030
Fax: 81-3-5488-3031

**Mentor
Graphics**

MGC - 08/07 1026160-w